

# Mini Polarization Maintaining RC Fiber Isolator

## Features

- Low Insertion Loss
- High Power Handling
- High Isolation
- High Reliability
- Low Cost

## Applications

- Fiber Laser
- Optical Fiber Amplifier
- Fiber Optical Sensor
- Instrumentation
- Compact Optical Circuits

## Specifications

Parameters	Unit	Values			
		Single Stage		Dual Stage	
Grade		Grade P	Grade A	Grade P	Grade A
Center Wavelength	nm	1550			
Operating Wavelength Range	nm	±20			
Typ. Peak Isolation	dB	40	38	52	50
Min. Isolation at 23°C	dB	28	26	42	40
Typ. Insertion Loss at 23°C	dB	0.4	0.5	0.5	0.65
Max. Insertion Loss	dB	0.6	0.7	0.7	0.9
Min. Return Loss (Input/Output)	dB	55 / 55	55 / 55	55 / 55	55 / 55
Min. Extinction Ratio (only for B Type)	dB	20	18	20	18
Min. Extinction Ratio (only for F Type)	dB	25	23	25	23
Max. Optical Power (CW)	mW	500			
Max. Tensile Load	N	5			
Fiber Type		RC PM 1550 Panda Fiber			
Operating Temperature	°C	-5 to +70			
Storage Temperature	°C	-40 to +85			

\*Above specifications are for device without connector.

\*The optical path is aligned to slow axis.

## Package Dimensions

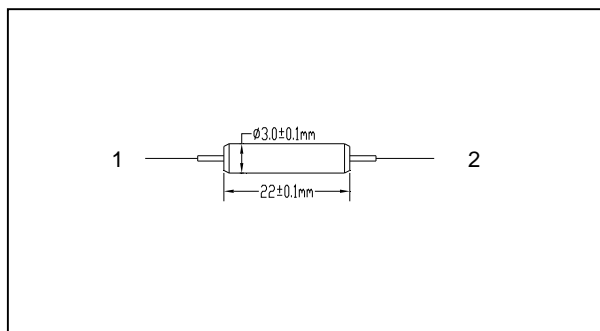

## Ordering Information

**MPMRCI-①①-②-③-④-⑤⑤-⑥⑥-⑦**

①①: Wavelength  
55 - 1550nm  
SS - Specify

④: Axis Alignment  
F - Fast Axis Blocked  
B - Both Axis Working

⑦: Fiber Length  
0.8 - 0.8m  
S - Specify

②: Grade  
P - Premium Grade  
A - A Grade

⑤⑤: Connector Type on Port 1 & 2  
N - None

③: Stage  
S - Single Stage  
D - Dual Stage

⑥⑥: Fiber Jacket on Port 1 & 2  
B - 170um Bare Fiber  
L - 900um Loose Tube  
S - Specify