

# Polarization Maintaining Filter Wavelength Division Multiplexer

## Features

Wide Pass Band  
 Low Insertion Loss  
 High Return Loss  
 Excellent Environmental Stability

## Applications

Fiber Lasers  
 Fiber Amplifiers  
 Fiber Sensors  
 Research

## Specifications

Parameters	Unit	Values	
Pass Band	Wavelength Range	nm	1520~1580
	Max. Insertion Loss	dB	0.7
	Typ. Insertion Loss	dB	0.5
	Min. Isolation	dB	25
	Typ. Isolation	dB	30
Reflection Band	Wavelength Range	nm	960~990
	Max. Insertion Loss	dB	0.5
	Typ. Insertion Loss	dB	0.3
	Min. Isolation	dB	12
	Typ. Isolation	dB	15
Min. Return Loss	dB	50	
Min. Directivity(over 960~990nm)	dB	60	
Min. Extinction Ratio	dB	20	
Typ. Extinction Ratio	dB	22	
Thermal Stability	dB/°C	≤0.005	
Max. Optical Power (CW)	mW	500	
Max. Tensile Load	N	5	
Fiber Type	PM 1550 Panda Fiber for Port 1/3, Hi 1060 Fiber for Port 2		
Operating Temperature	°C	-5 to +70	
Storage Temperature	°C	-40 to +85	

\*Above specifications are for device without connector.

\*For devices with connectors, IL will be 0.3dB higher, ER will be 2dB lower and RL will be 5dB lower.

\*The PM fiber and the connector key are aligned to the slow axis.

## Package Dimensions

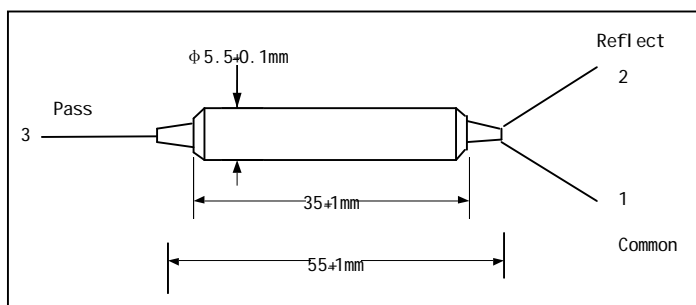

## Ordering Information

**PMFWDM-①①①①-②②②-③③③-④**

①①①①: Wavelength  
 5598 - 1550nm Pass / 980nm Reflect

②②②: Connector Type on Port 1, 2 & 3  
 1 - FC/UPC  
 2 - FC/APC  
 3 - SC/UPC  
 4 - SC/APC  
 N - None  
 S - Specify

③③③: Fiber Jacket on Port 1, 2 & 3

B - 250um Bare Fiber  
 L - 900um Loose Tube  
 S - Specify

④: Fiber Length  
 0.8 - 0.8m  
 S - Specify